

LOOKBOOK

2026

MAWAZIN موازين

DISCOVER YOUR IDEAL MAWAZIN SETTING.

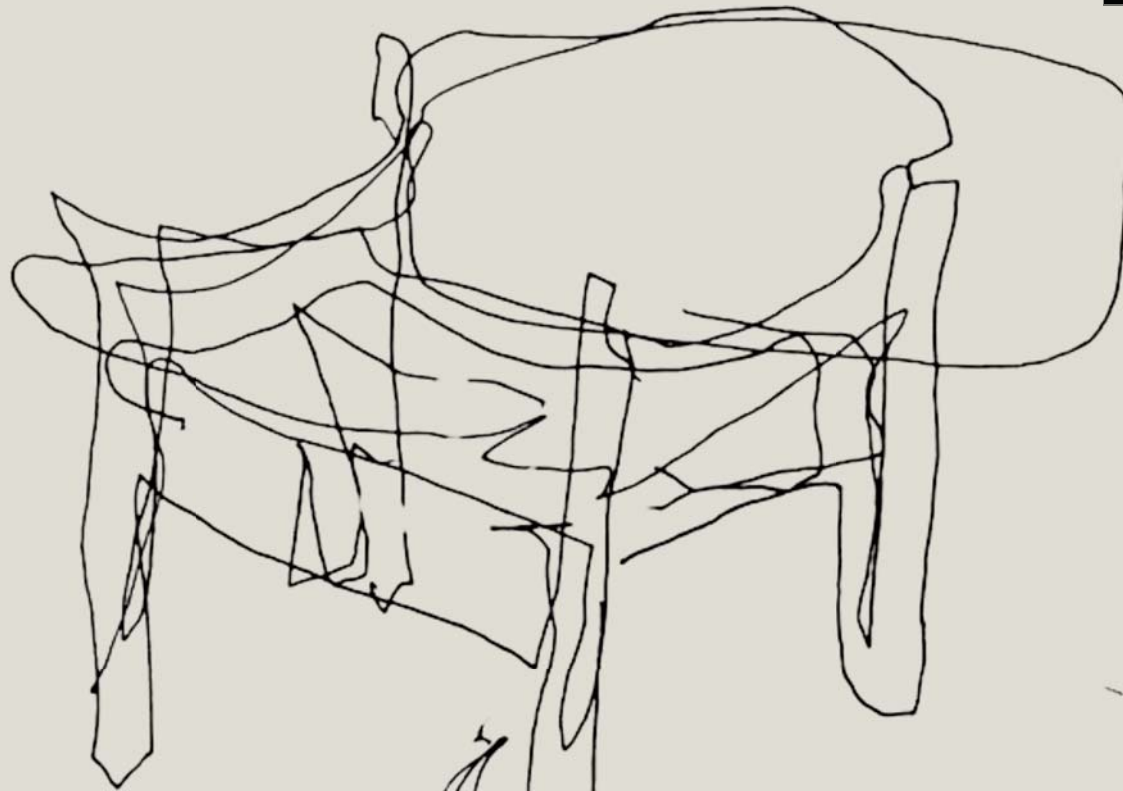

BALANCED
BY -
DESIGN

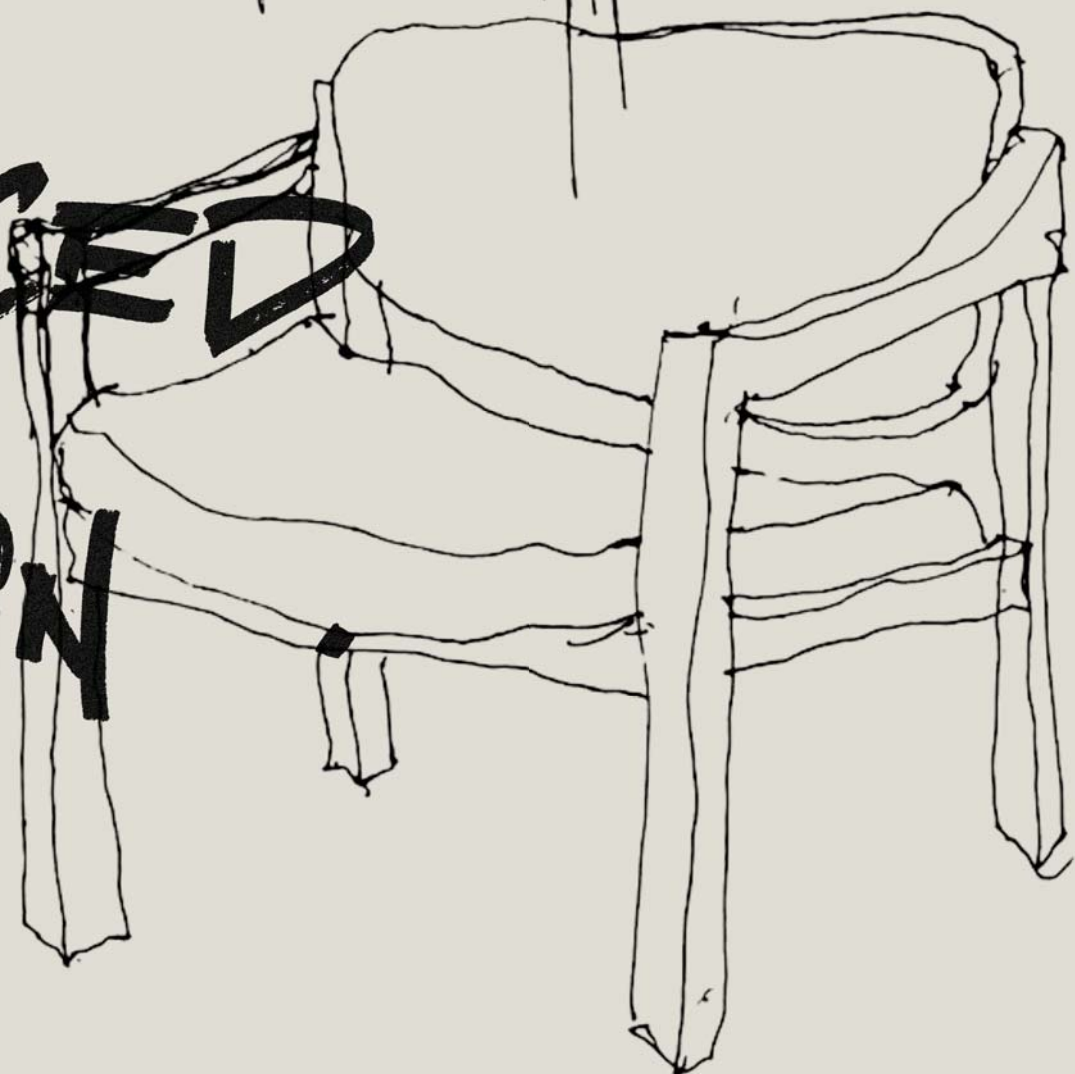



Mawazin is not simply outdoor furniture.

It is a study of balance between architecture, material, atmosphere, and human presence.

Rooted in craftsmanship and guided by quiet geometry, the collection explores how outdoor living can feel grounded, refined, and timeless. Each piece is designed with a restrained architectural language solid teak wood, woven rope textures, and carefully balanced proportions that respond naturally to light, shadow, and landscape.

Inspired by raw environments, warm earth tones, and contemporary mediterranean living, mawazin creates spaces that feel calm, tactile, and enduring. The collection embraces simplicity without losing character, allowing materials and form to speak with honesty.

Every detail is intentional.

Every proportion is measured.

Every texture is designed to age beautifully with time.

More than furniture, mawazin is an atmosphere one that brings balance to outdoor living through craftsmanship, material authenticity, and architectural clarity.



emotion,

rawness

and

refinement.



THE BRAND'S NATURE

- BEHIND THE NAME

EVERYTHING
OF
-
BIT
LITTLE
A

In every form we shape, in every line we draw, and in every joint we make — there is **balance.**

Mawazin is not just a name. It is a worldview. A philosophy born out of building slowly, precisely, and with deep respect for material, structure, and life.

Founded by the architect Ahmed El Attar, who has spent over a decade crafting space and structure, Mawazin reflects his lived experience one foot in concept, the other in construction. With a workshop rooted in Alexandria and a reputation built across Egypt and the Gulf, the maker behind the brand has spent years building terraces, cladding facades, and designing large-scale outdoor furniture. But now, Mawazin marks a turning point — a return to essence. To the grain. To the object.

Mawazin is not trendy. It is not decorative. It does not follow.

It balances. It builds. It holds.

It is the quiet force behind honest furniture — designed to support, not perform.

It celebrates the act of making as a form of thought. It reflects a lifestyle of balance between the work and the pause, the object and the space, the individual and the collective.

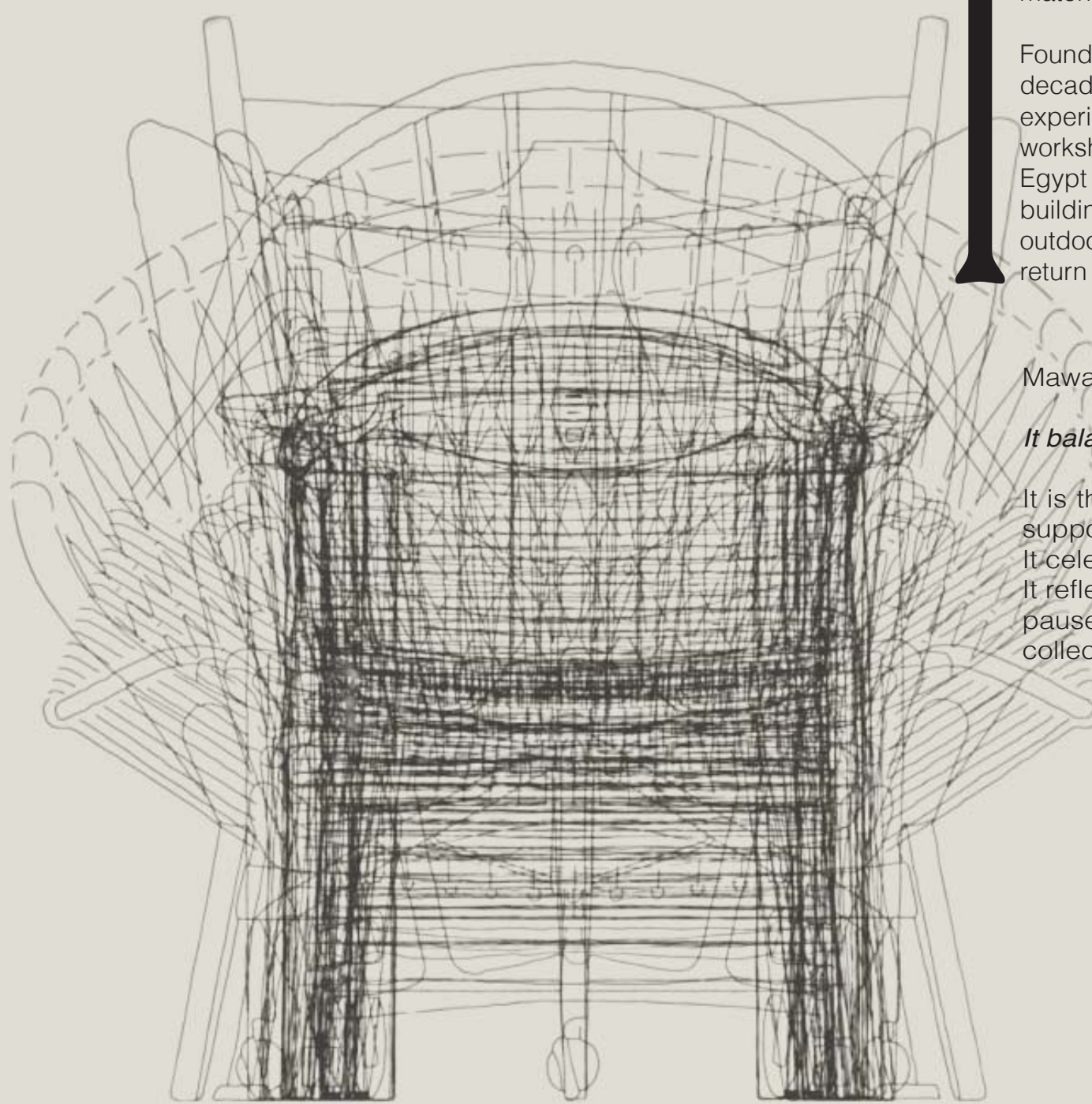

CONTENTS



Available at
WWW.BYMAWAZIN.COM

® **Mawazin** is where balance becomes design. Not just symmetry, but precision knowing what to refine, what to release, and how to bring every element into perfect harmony.



NEW COLECTION
COMING SOON >>



01 .
SIDE TABLES .

BY
**cherif.
morsi**



03 .
ARM CHAIRS .

02 .
COFFEE
TABLES .



05 .
SOFAS & ARM
CHAIRS .



04 .
DINING SETS .

“EXPLORE OUR RANGE OF PRODUCTS.”

01



08

02



04

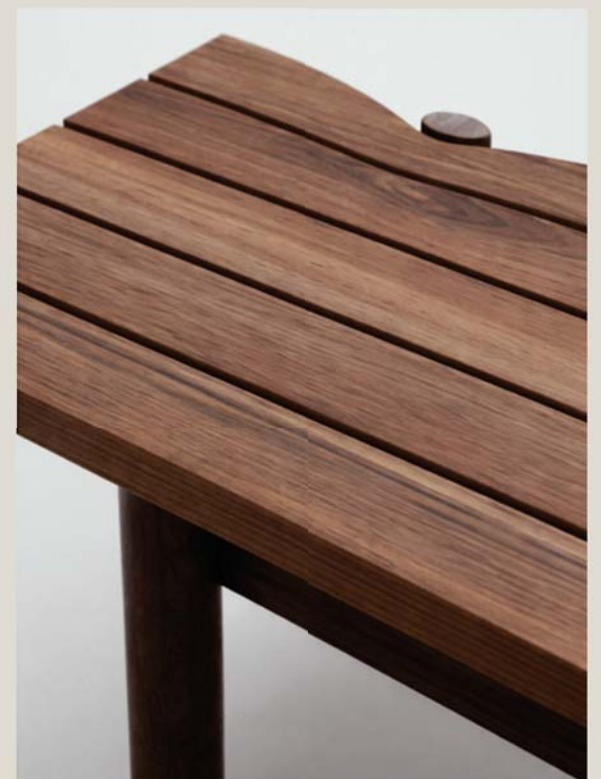

03

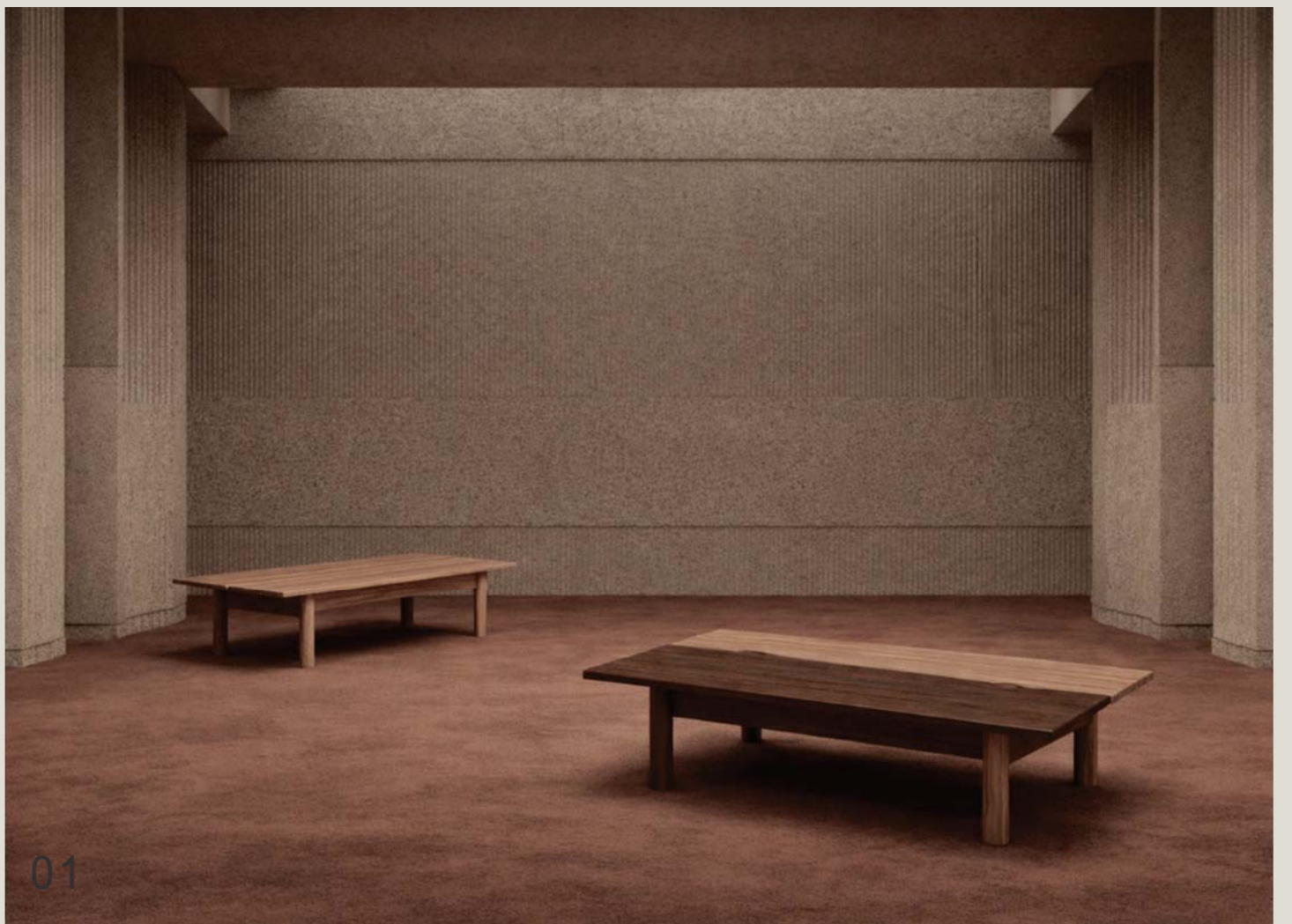

DISCOVER OUR
NEW COLLECTION
NOW AVAILABLE
ONLINE AT
WWW.BYMAWAZIN.COM



02



NEW COLLECTION

NEW COLLECTION

NEW COLLECTION

NEW COLL



03



09

B A S S M A



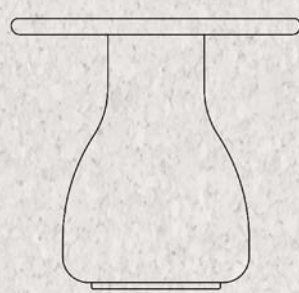
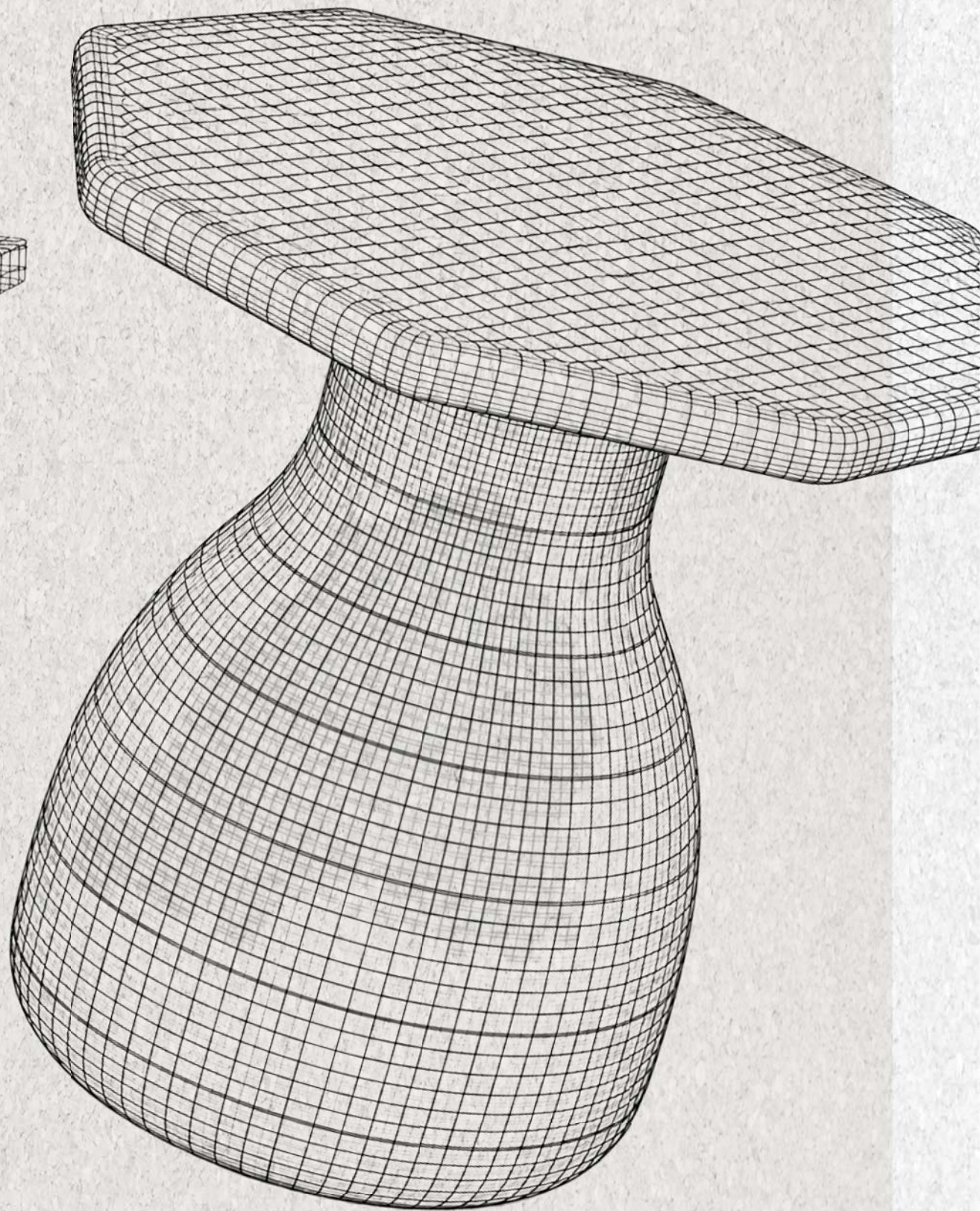
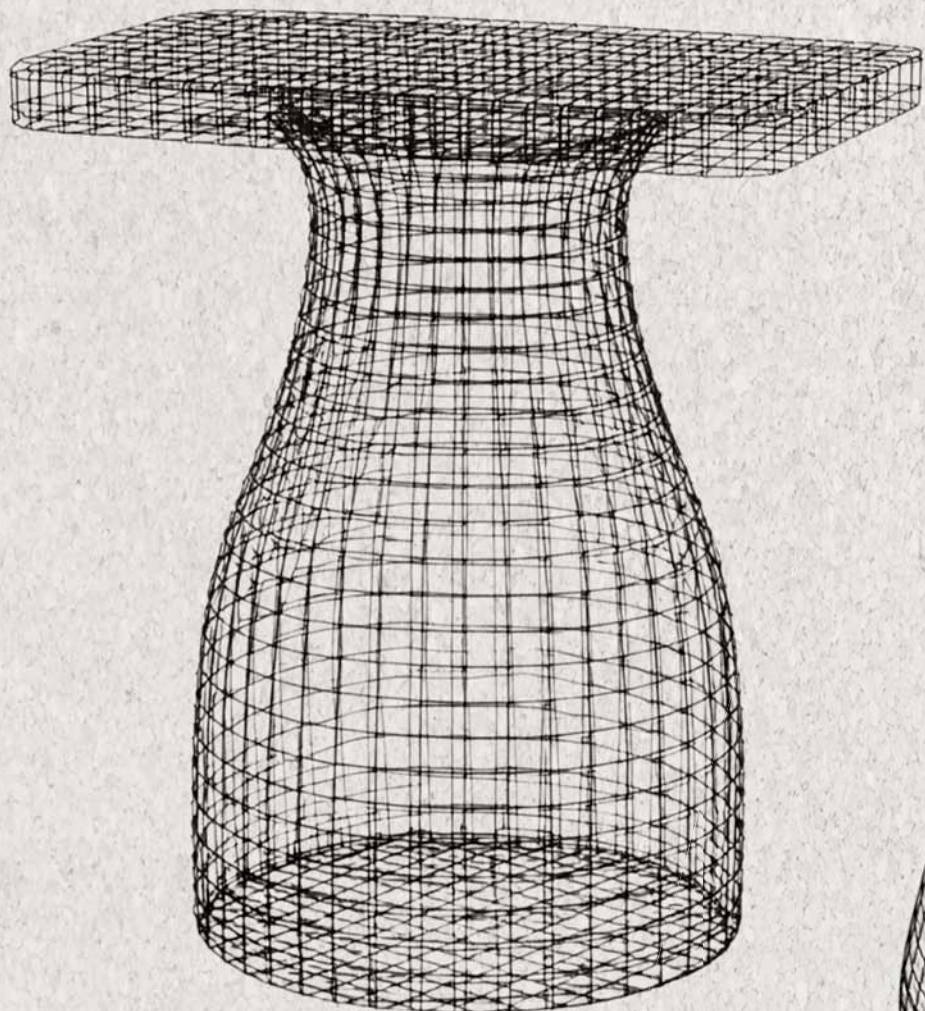

FRONT VIEW



42.0

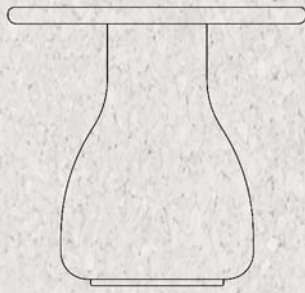

FRONT VIEW



42.0

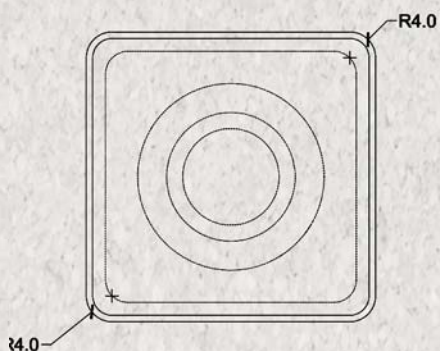

R4.0

45.0

TOP VIEW

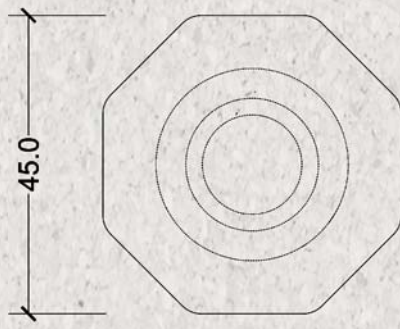

R4.0

45.0

45.0

TOP VIEW

BASSMA side table is a sculptural, monolithic wooden piece that blends function with artistic expression.

Designed with a softly irregular top and a tapered pedestal base, it embraces organic geometry and natural balance. Crafted from solid wood with a matte finish, basma highlights rich grain patterns and subtle imperfections, giving each piece a unique, handcrafted character. Ideal as an accent or side table, it brings a warm, modern-organic presence to any

E N S E Y A B



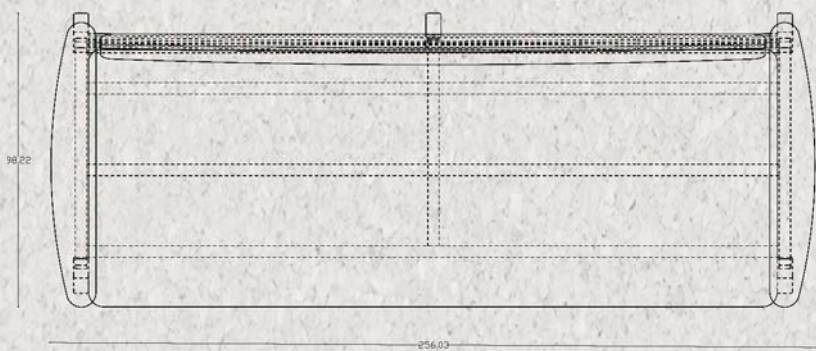
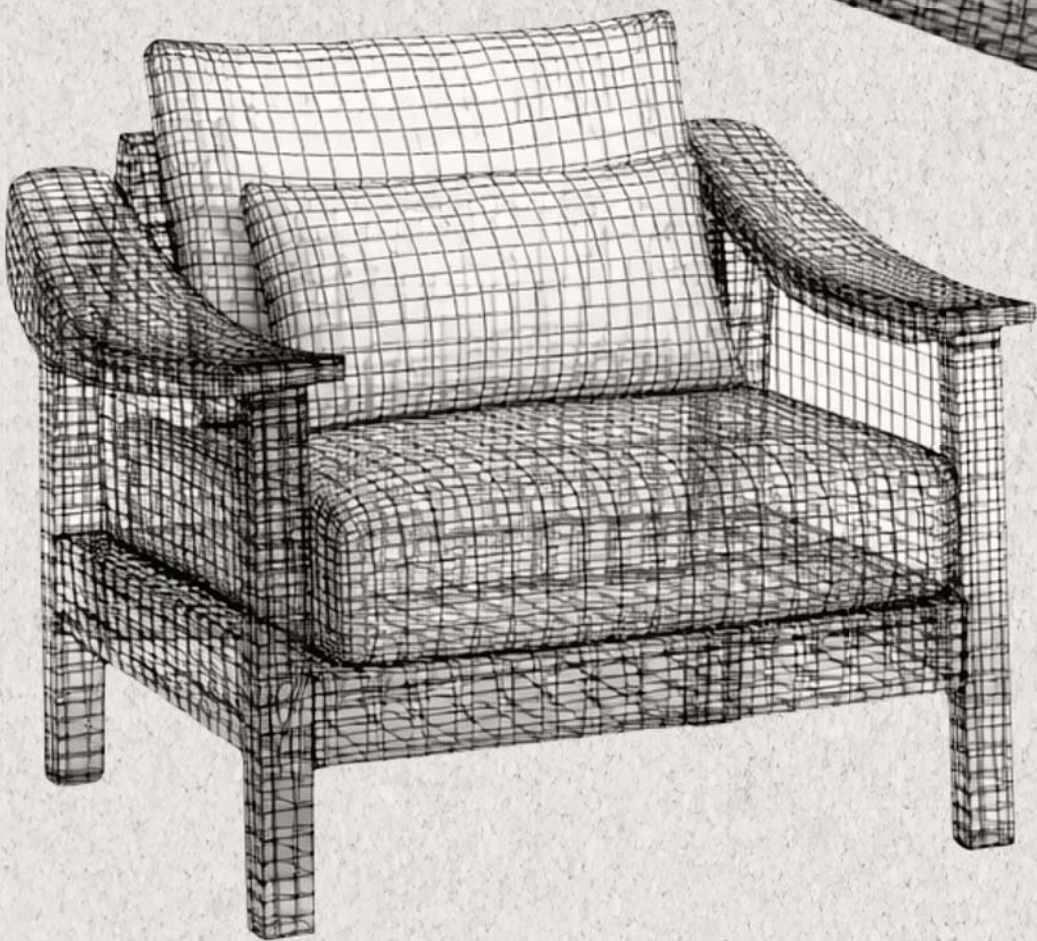
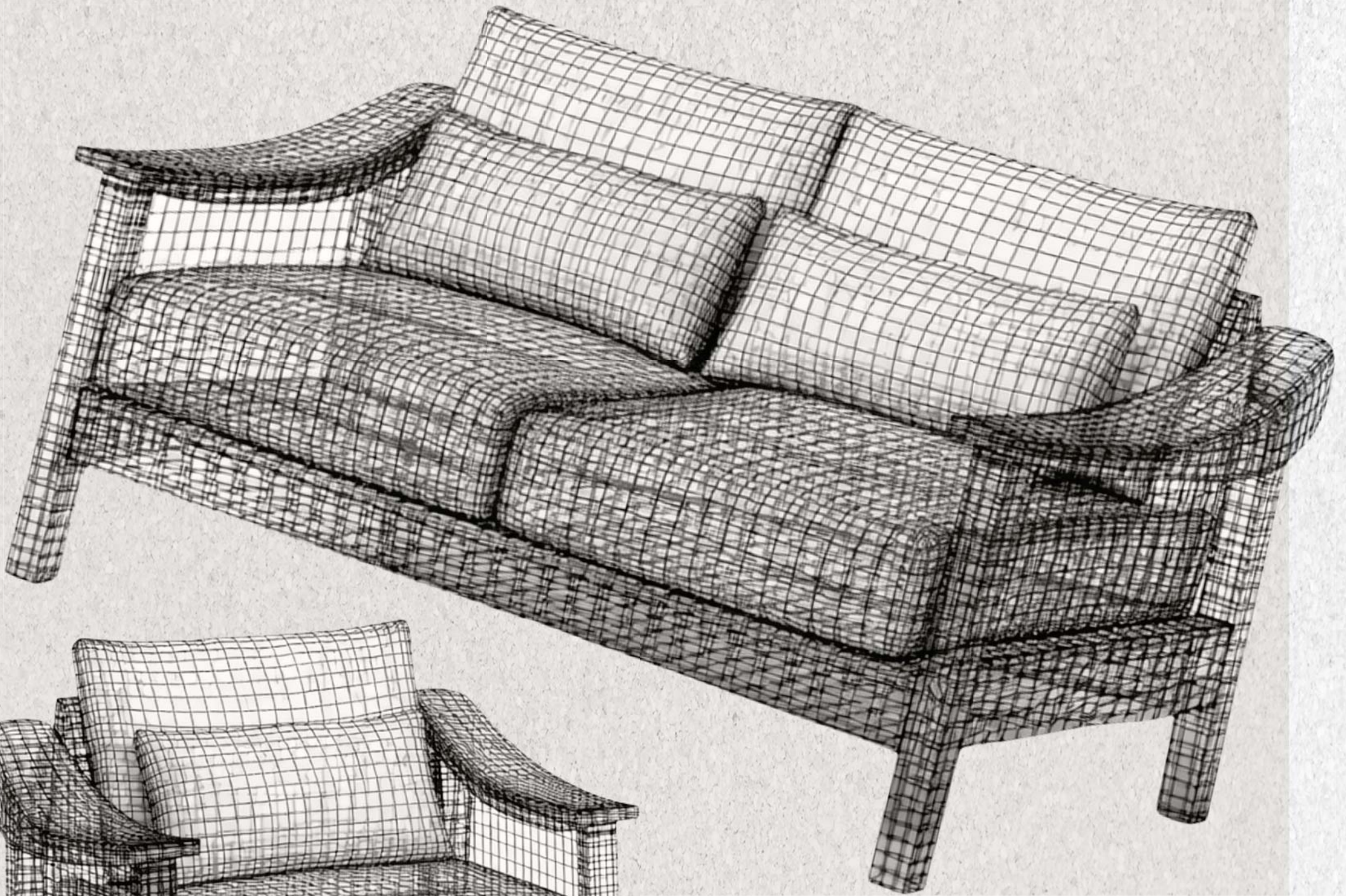

TOP VIEW

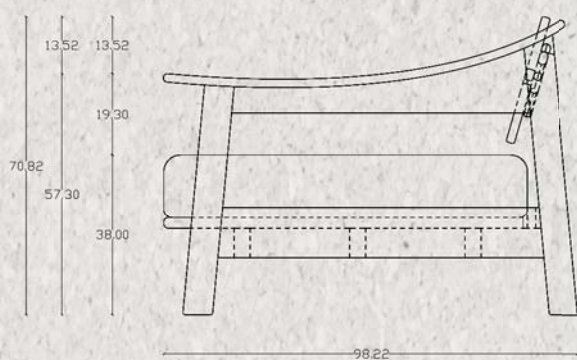

SIDE VIEW

ENSEYAB seating collection is a refined wooden sofa and armchair set defined by its smooth, flowing armrest lines and balanced proportions.

Crafted from solid wood with a warm natural finish, the design emphasizes comfort through deep seating and soft upholstered cushions, while maintaining a clean, modern-organic aesthetic. Enseyab blends structural strength with visual lightness, creating a timeless piece suited for both relaxed outdoor living and sophisticated interiors.



W A T H E E R



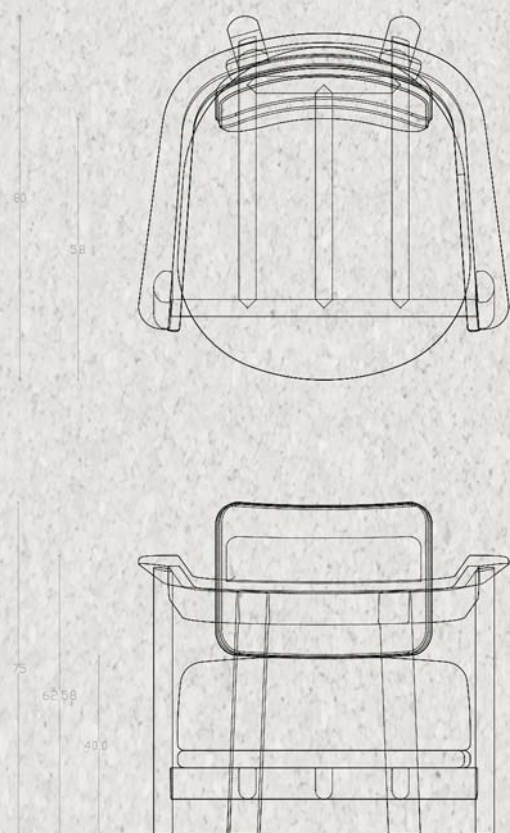
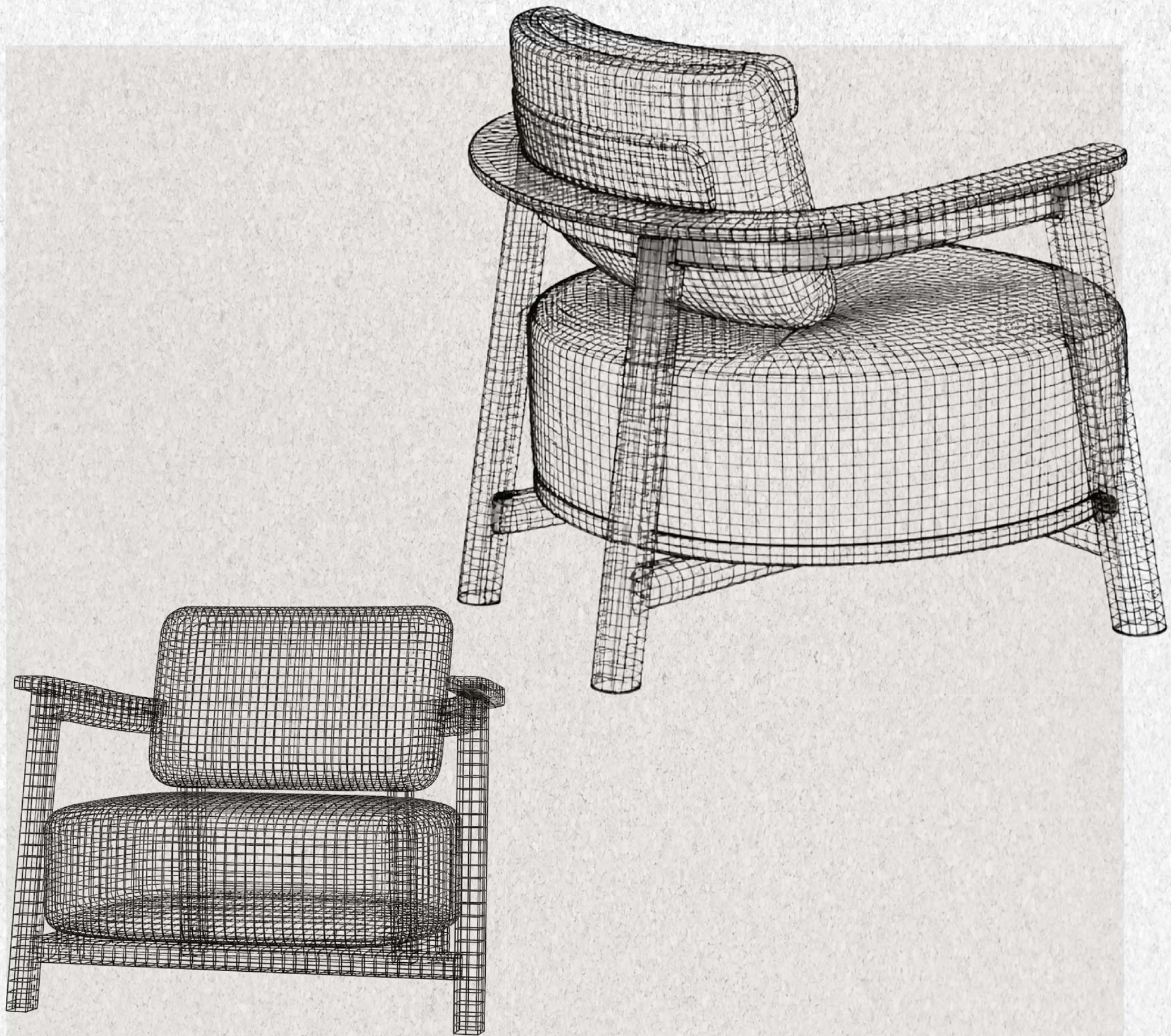

WATHEER is a refined expression of contemporary outdoor lounging, where sculptural simplicity meets tactile warmth. Crafted from solid wood with a rich, natural finish its low-slung silhouette is softened by generously rounded cushions, creating a balanced dialogue between structure and comfort. The design emphasizes openness and flow, with gently curved armrests that frame the seating experience while maintaining a light, breathable presence making atheer an understated yet distinctive statement in modern outdoor living.

جیتھے
J E T H A E



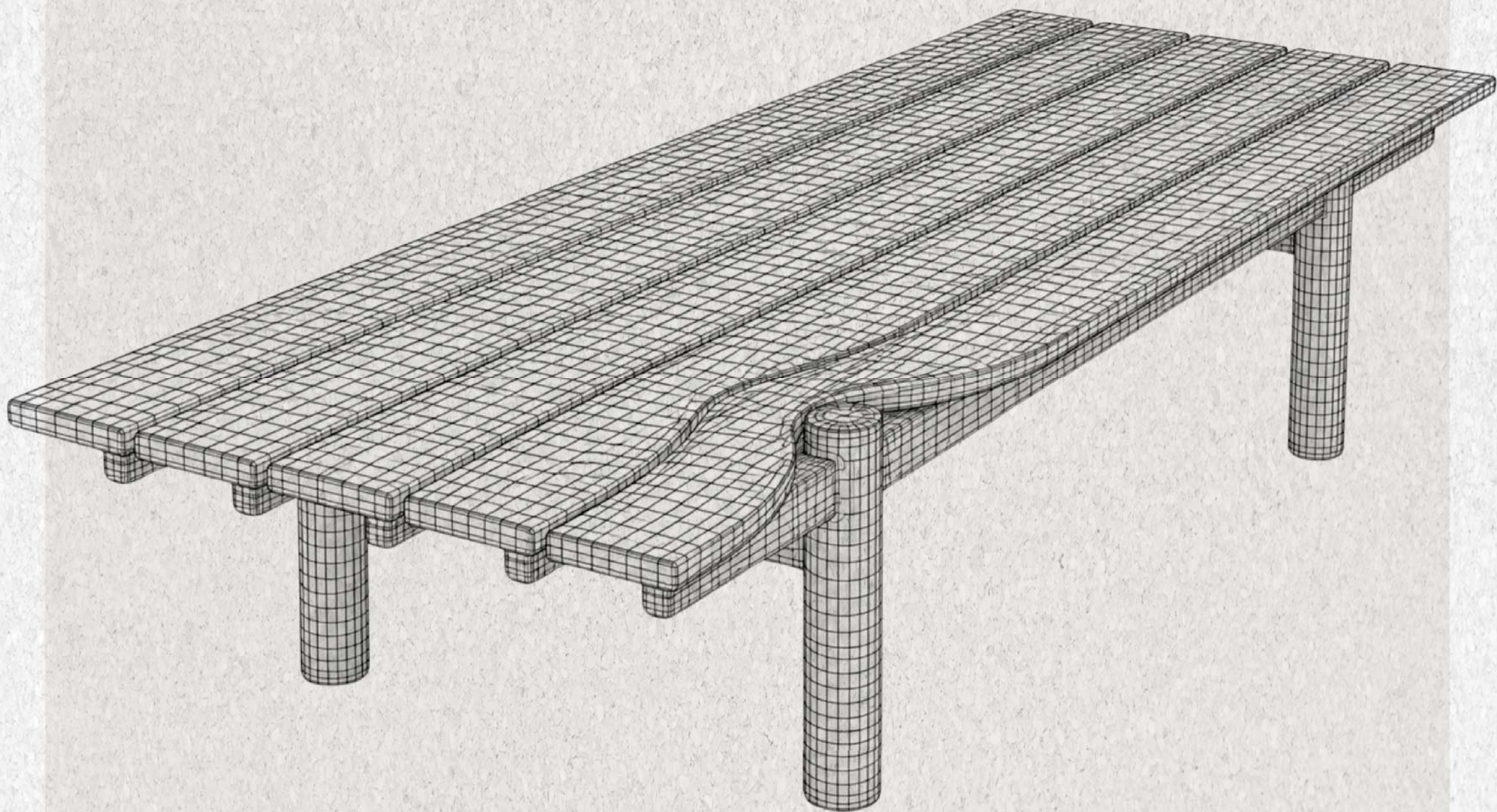

FRONT VIEW

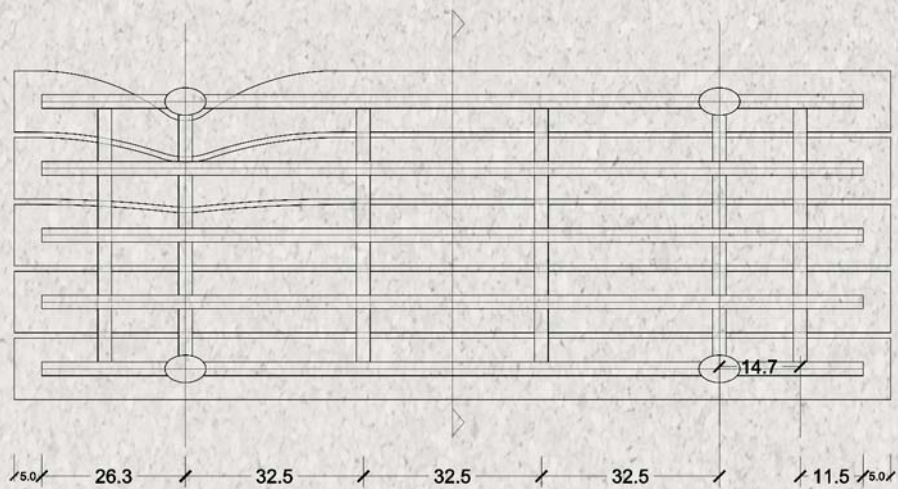

BOTTOM VIEW
(UNFILLETED)

JETHAE is a quiet celebration of craftsmanship, where clean geometry meets subtle sculptural detail. Defined by its rhythmic wooden slats and gently carved edge transitions the table introduces a sense of movement within a grounded, low-profile form. Crafted from solid wood with a warm, natural finish, it balances durability with refined simplicity offering a timeless centerpiece that seamlessly integrates into contemporary outdoor environments.

فَوَاتِر

W A T A R



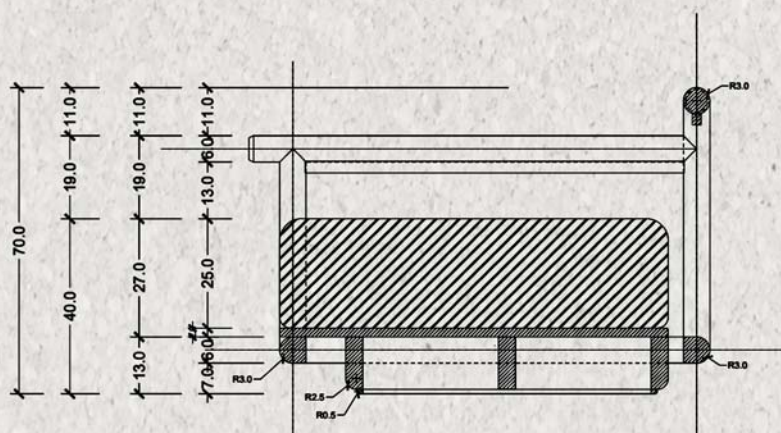
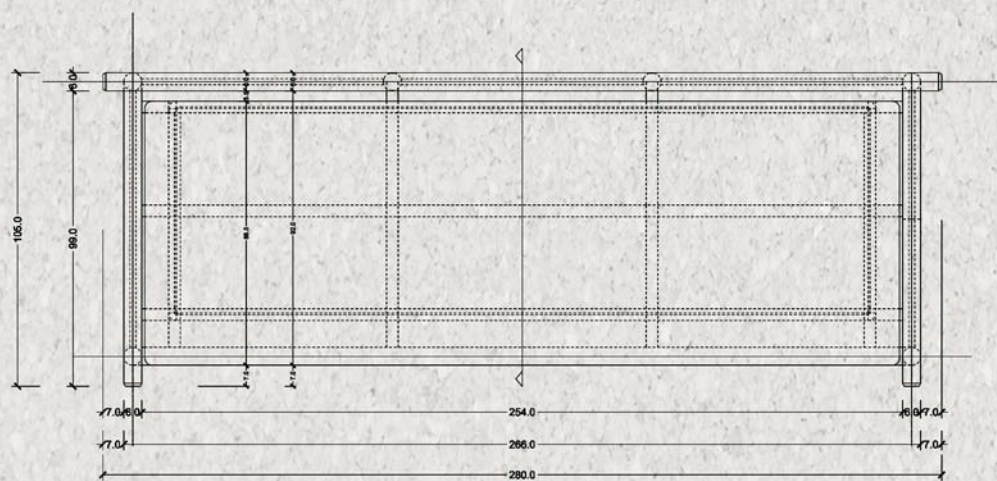
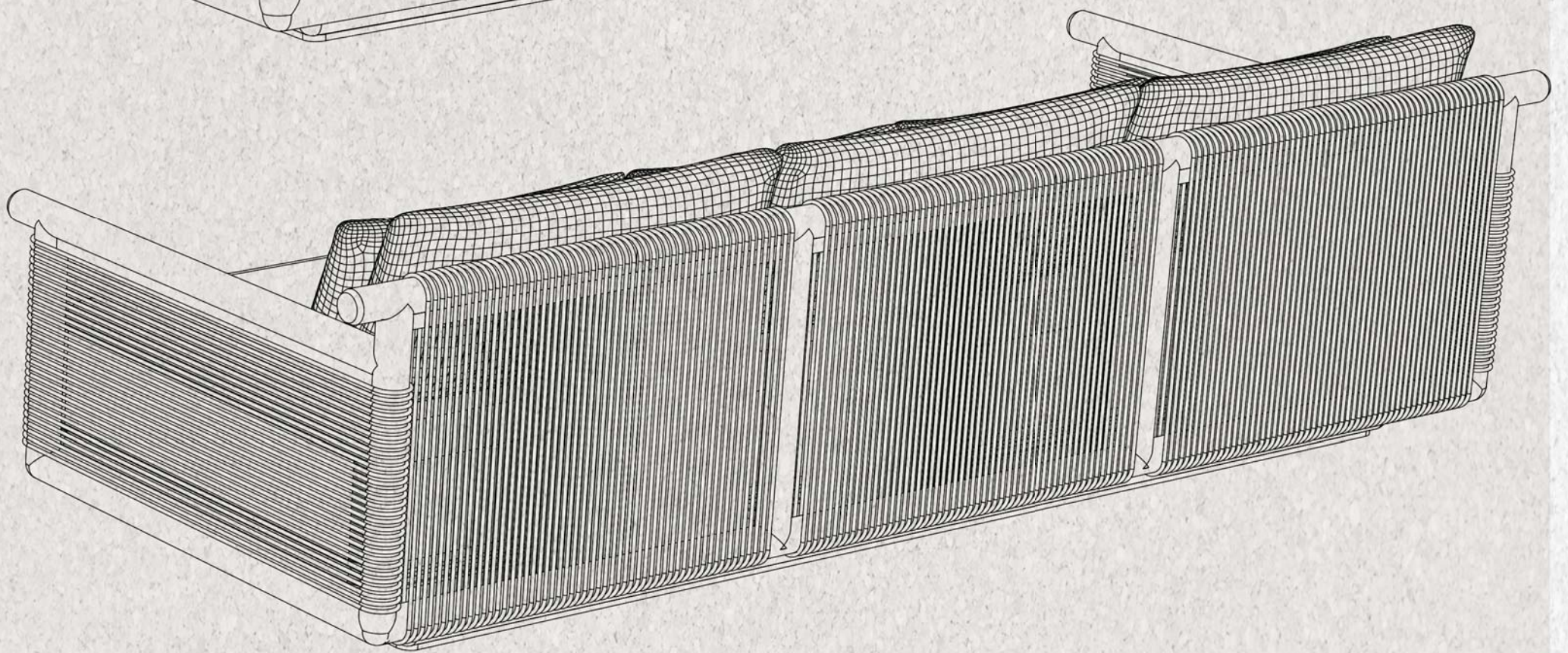
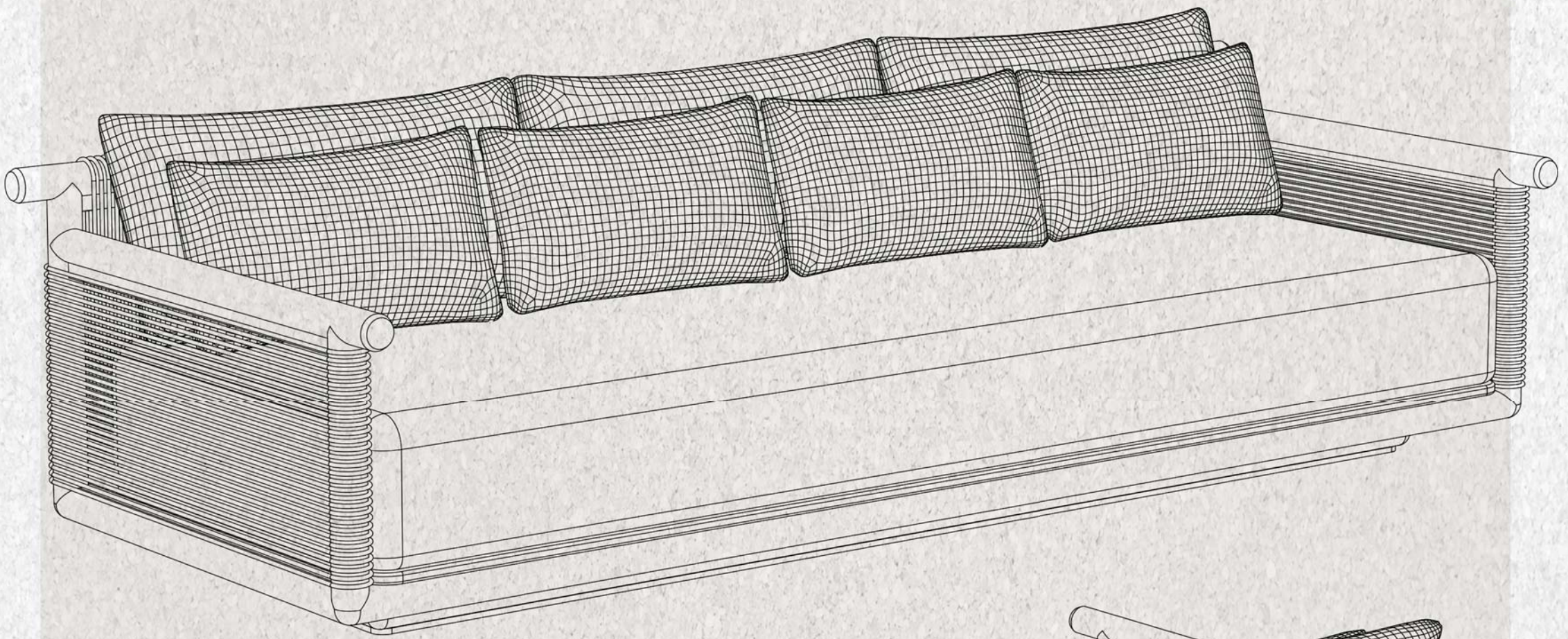

WATAR is a bold interplay of structure and texture, where precision-crafted wood frames are enveloped by a rhythmic rope weave that defines both form and identity

The linear wrapping creates a dynamic visual screen simultaneously solid and transparent while subtle color accents introduce depth and character. Anchored by soft, generous cushions, the design balances architectural rigor with inviting comfort, making rakeen a distinctive statement piece in contemporary outdoor living.

M. A. D. A. R

مَدَار



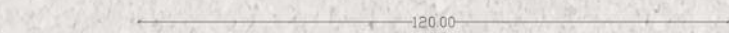
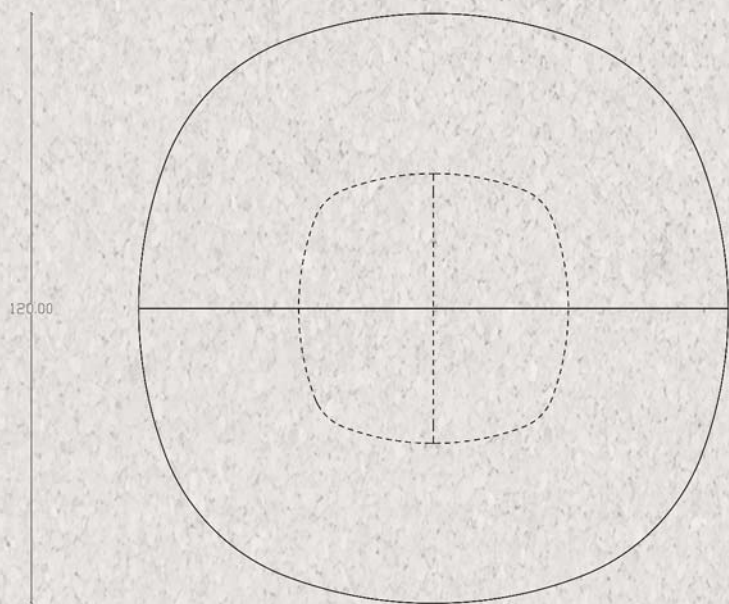
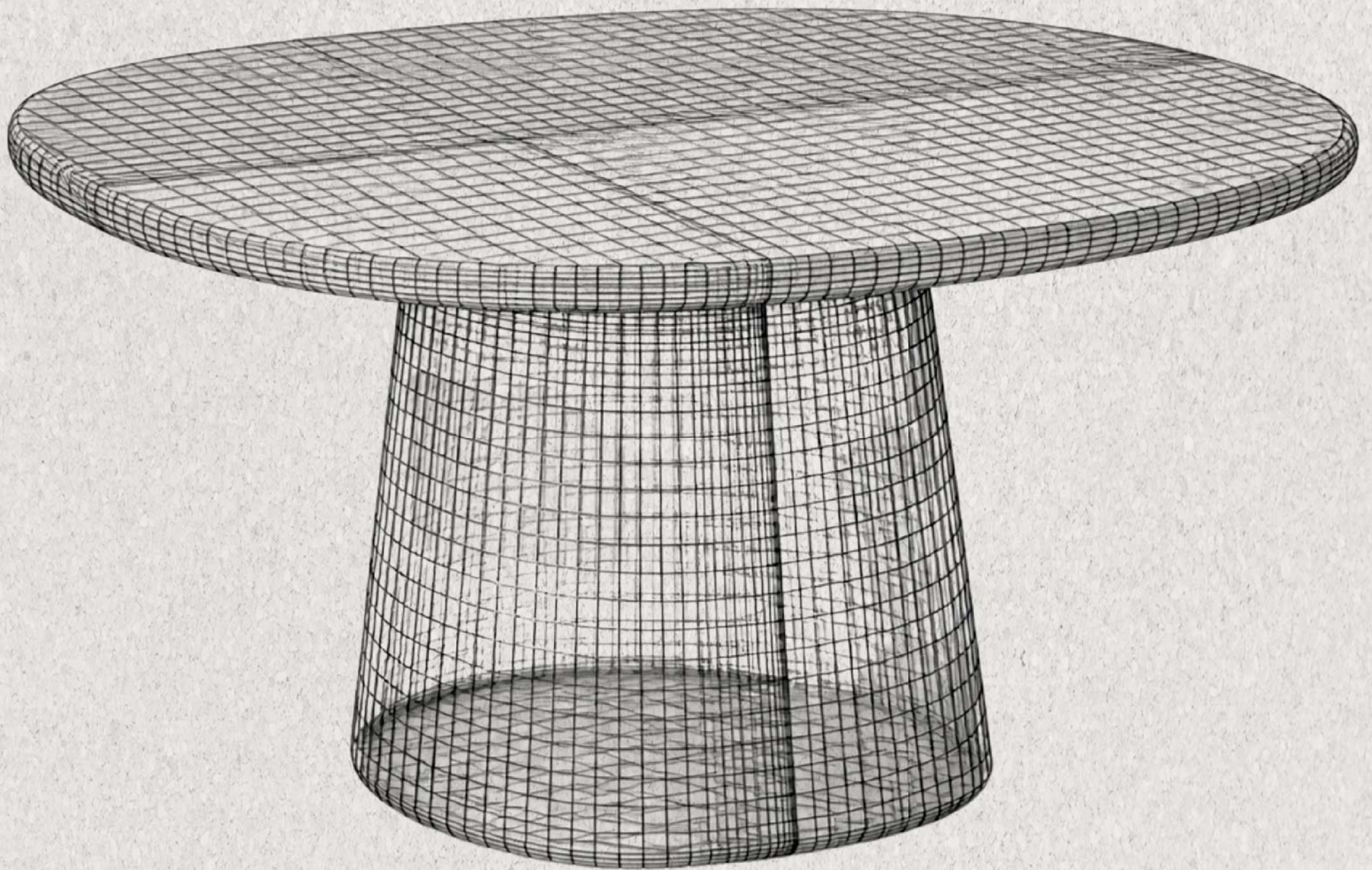

TOP VIEW

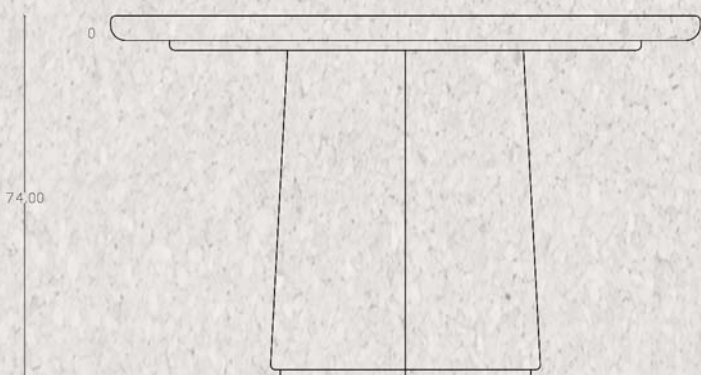

74.00

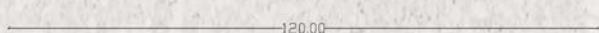

MADAR is a warm, contemporary dining statement defined by its sculptural simplicity and inviting materiality. Centered around a solid cylindrical base, the table anchors the space with quiet strength, while the softly rounded top enhances flow and interaction. Paired with compact, gently contoured chairs, the design balances robustness with comfort, showcasing natural wood textures and subtle upholstery accents creating an intimate setting that feels both modern and timeless.



REBATA

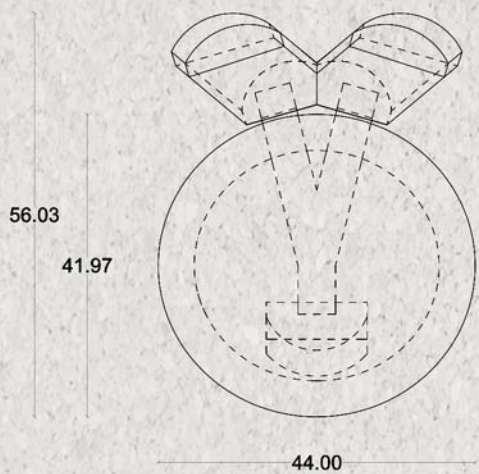
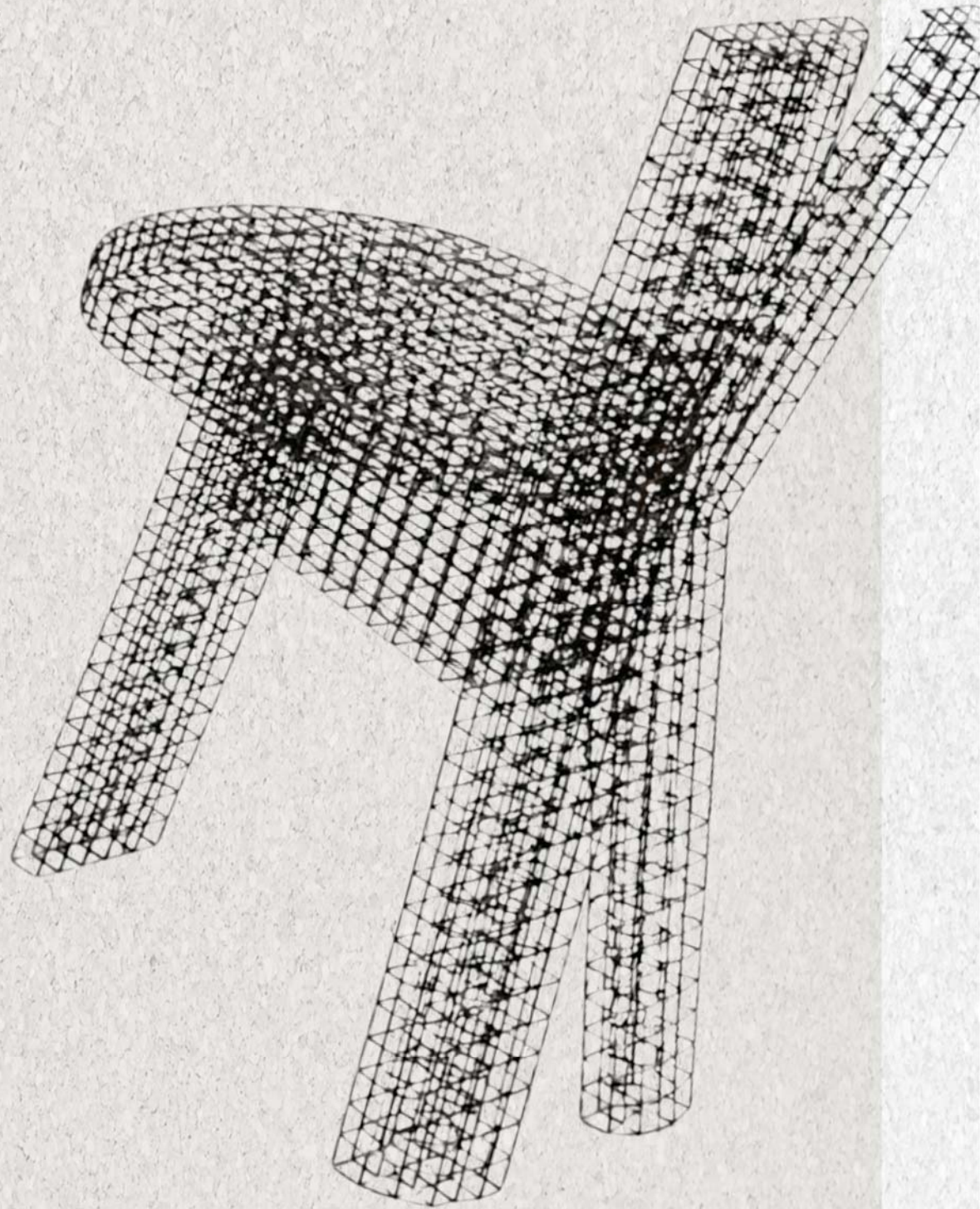
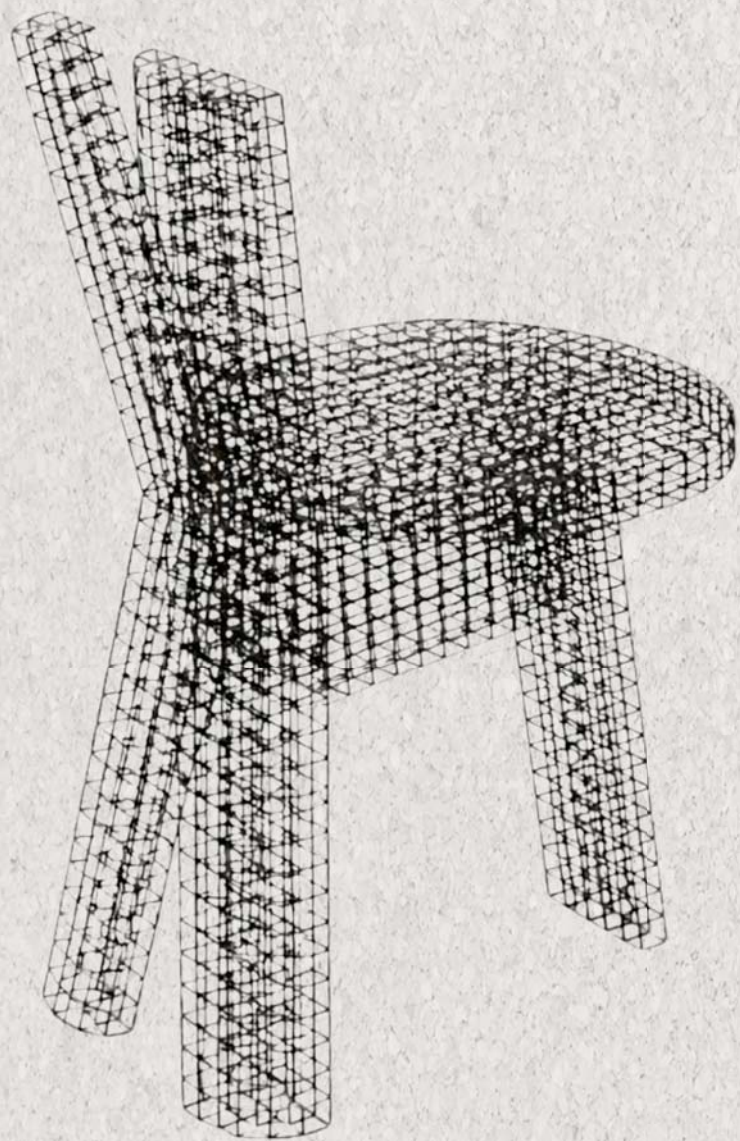

TOP VIEW

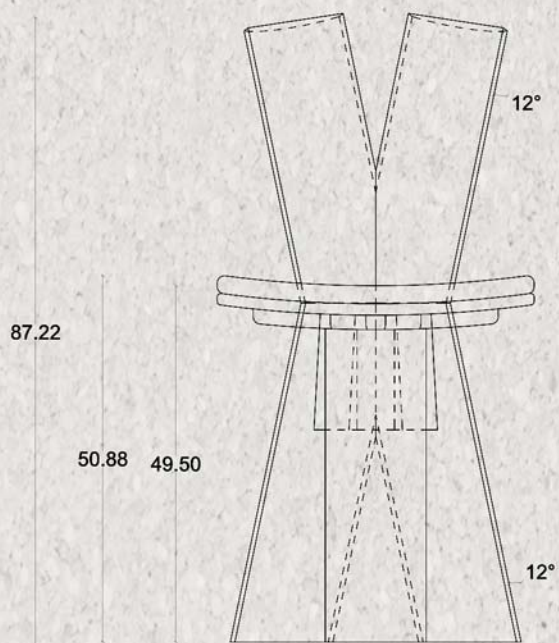

FRONT VIEW

REBAT A sculptural expression of balance and material honesty, this chair is defined by its bold solid-wood construction and distinctive X-structured rear legs that create both stability and visual tension. The thick, dark-stained timber reveals a rich natural grain, contrasted by a finely woven beige seat that introduces warmth and tactile softness. Slightly angled for ergonomic support, the backrest maintains a restrained geometric clarity, aligning with the chair's architectural character. Designed as both a functional object and a spatial statement, it sits comfortably within minimal interiors while asserting a strong, grounded presence.

R A S E E K H



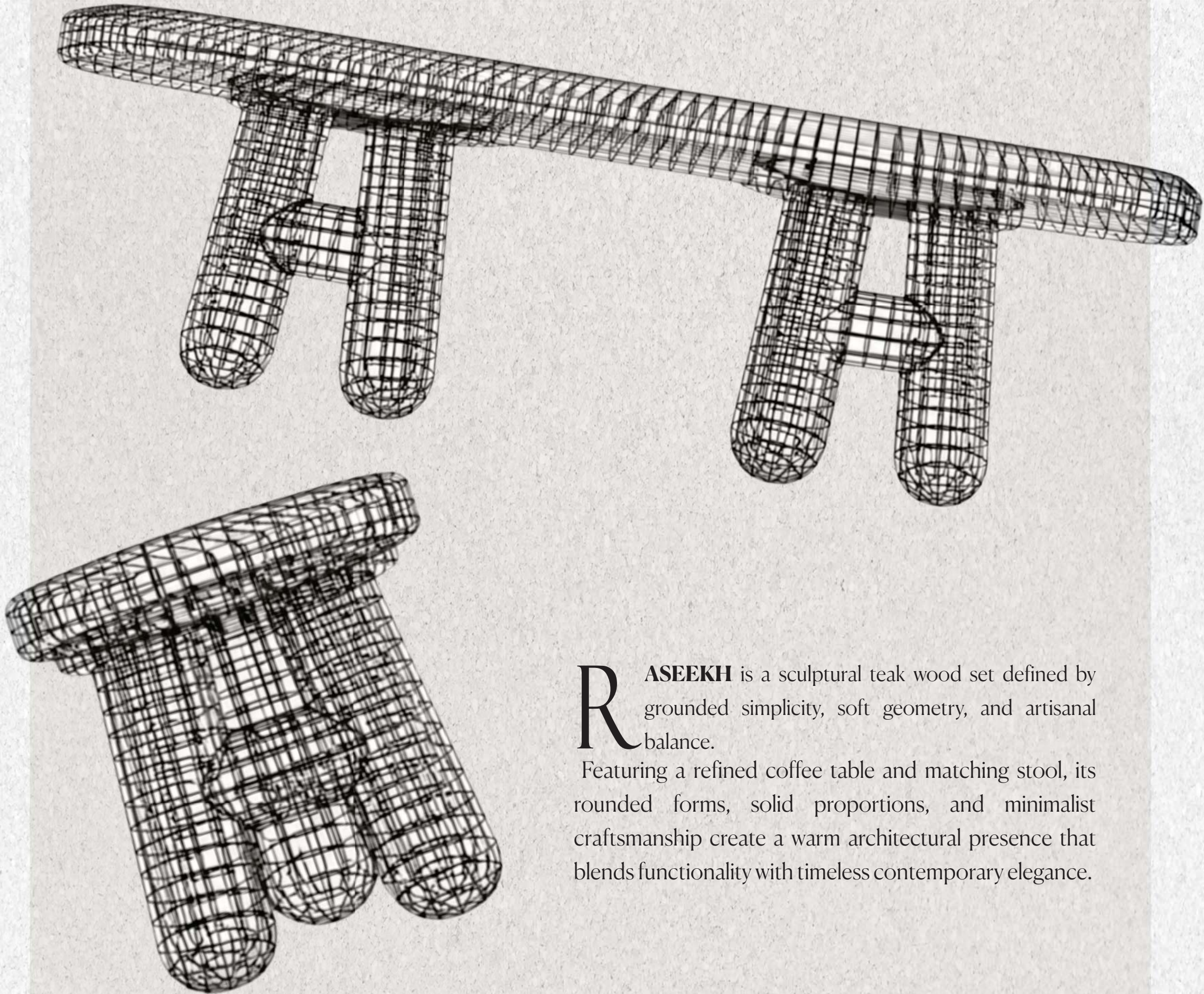

R ASEEKH is a sculptural teak wood set defined by grounded simplicity, soft geometry, and artisanal balance.

Featuring a refined coffee table and matching stool, its rounded forms, solid proportions, and minimalist craftsmanship create a warm architectural presence that blends functionality with timeless contemporary elegance.

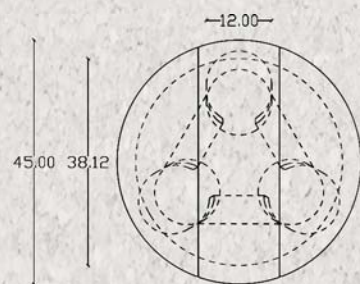

TOP VIEW

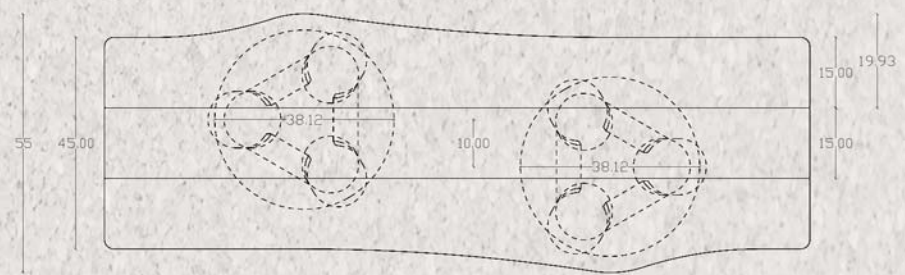

TOP VIEW

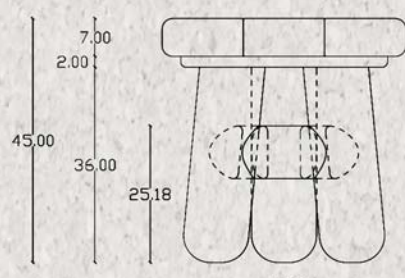

FRONT VIEW

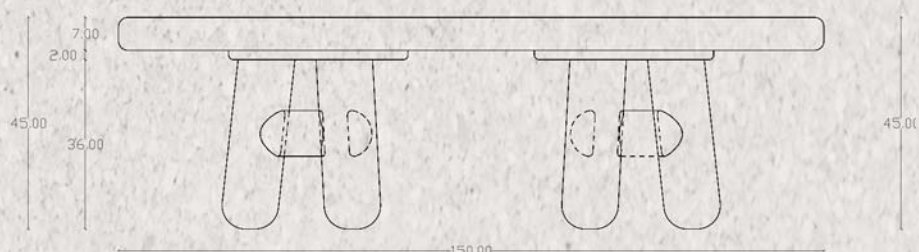

FRONT VIEW

N A F A S



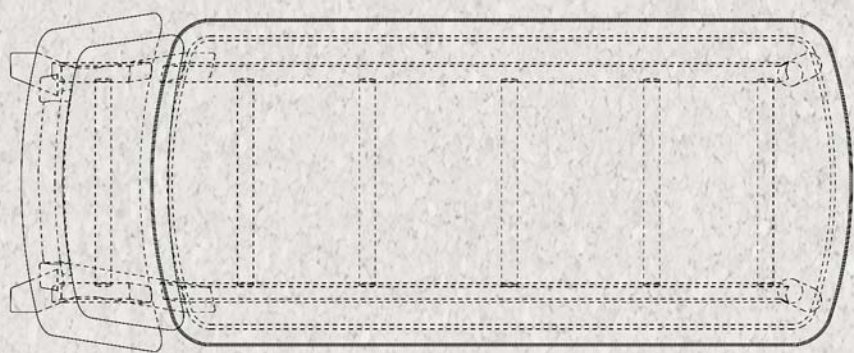
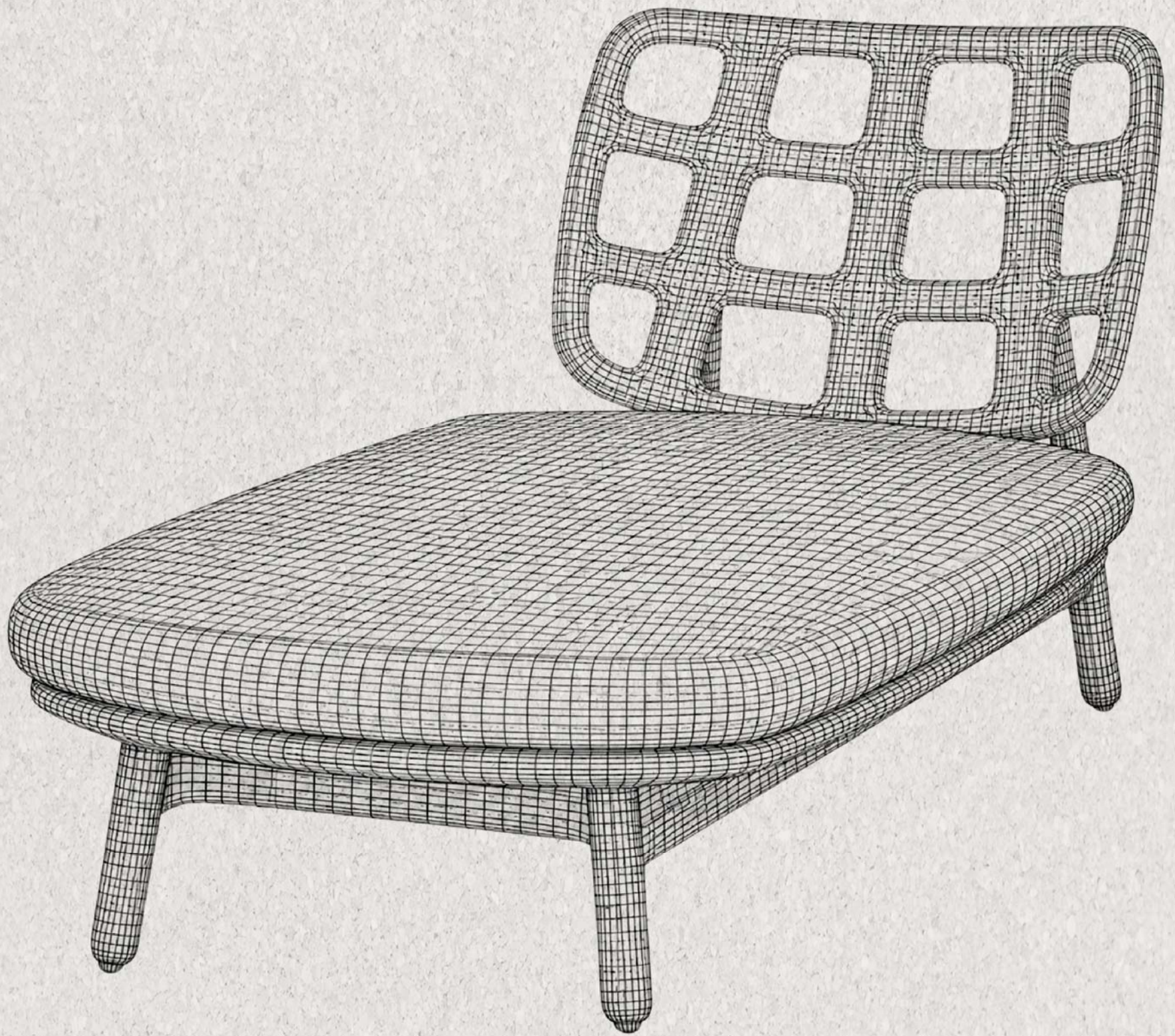

TOP VIEW

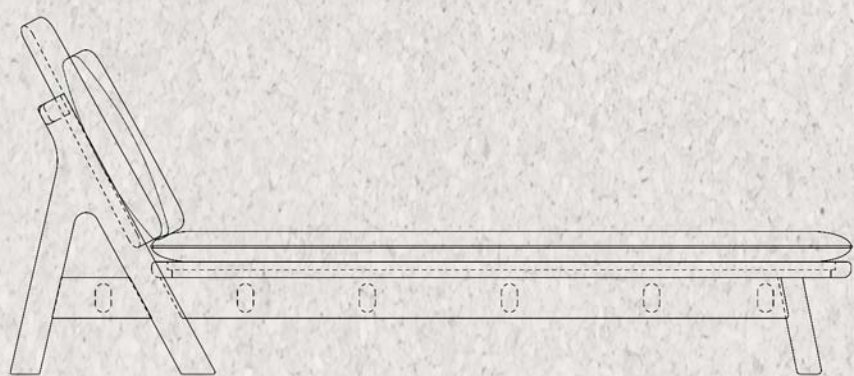

FRONT VIEW

NAFAS is a low-profile outdoor sunbed defined by clean horizontal lines and a grounded, architectural stance. The solid wood frame expresses warmth and durability, while the open grid backrest introduces lightness and ventilation, creating a balanced visual rhythm. A generously proportioned cushioned surface enhances comfort without compromising the minimal aesthetic. Designed for calm, sunlit environments, it embodies a quiet dialogue between structure and softness, function and form.

“THE MAKER

MAwazin, is a brand built on balance between design and function, tradition and modern living, craftsmanship and clarity. We don't see ourselves as manufacturers we see ourselves as makers. Every piece that leaves our hands carries a part of our process, our decisions, and our respect for material. We choose teak for its honesty, shape it with intention, and refine every detail until it feels balanced, natural, and right. What you receive is not just outdoor furniture, but something we've carefully built to live with you, age with you, and belong in its environment. This is our work, and this is how we stand behind it.

Every piece begins with intention and ends with presence. We design outdoor furniture not just to occupy space, but to create balance between material, environment, and human experience. Through carefully selected teak, hand-finished details, and honest construction, each product reflects a commitment to durability, comfort, and quiet elegance. Our work is rooted in craftsmanship and guided by proportion, ensuring that every form feels natural in its setting. This is not just furniture it is a considered extension of how you live outdoors.

This brand is my response to a world that moves too fast. Through mawazin, we slow down. We pay attention. We build with intention.

What you see here is the result of many minds and hands; designers, craftsmen, collaborators, all working with a shared devotion to balance and beauty.

Thank you for letting our work become part of your story.
Thank you for listening to the wood .



feeling
inspired

Step into our world of outdoor luxury at any moment and discover your ideal Mawāziṅ setting.

CONTACT US

info@bymawazin.com

+20 111 245 3490

+966 50 957 1545

MAIN OFFICE Cairo: Centrada Mall Zayed Unit DA202
Cairo : Mivida Compound, Boulevard, Parcel 40-C02
Alexandria: 34 Hatem Mosque, Smouha St.
Riyadh: 7250 King Fahd Rd., Al Olaya District



WWW.BYMAWAZIN.COM

